

# PRORIL

50 Hz

Designed for light weight, excellent performance, low energy consumption, and easy maintenance, PRORIL submersible handy pumps serve a wide range of pumping applications on utility, construction, industrial, and municipal job sites.

Handy and Residue Pump

## SMART LITE 400

Handy Pump



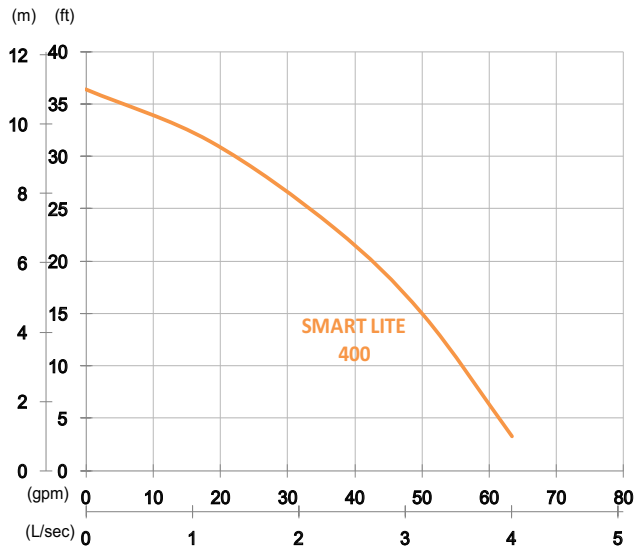

Shaft Speed : 2850 rpm

Outlet : 50mm, 2in

OUTPUT	HEAD	FLOW
0.4 kW	Rated : 7m, 23ft	Rated : 2.3 L/s, 37 gpm
0.5 HP	Max : 11m, 36ft	Max : 4 L/s, 63 gpm

Solid Passage : 7 mm, 0.3 in

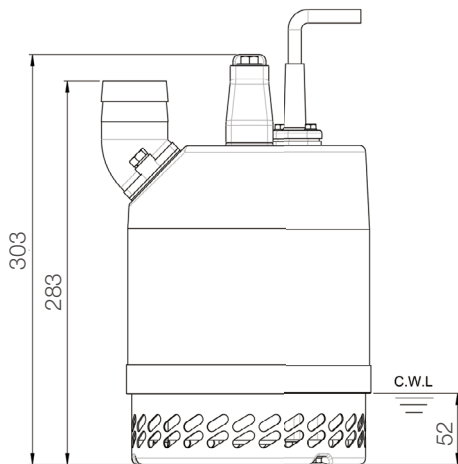
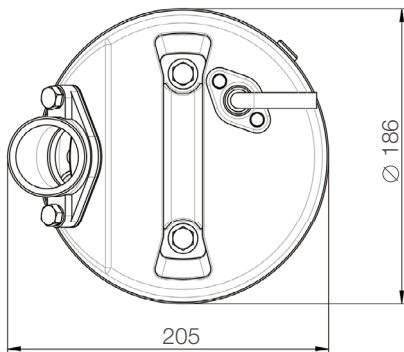

unit : mm

Weight : 11kg / 25 lbs

Pump Type		Electric Submersible Pumps
		1-Phase
Motor	Type	Induction Motor
	Poles	2 Pole
	Insulation	Class F
	Protector	Miniature Thermal Protector
	Starter	Capacitor-Run
Lubricant		Food Grade (ISO VG32)
Impeller Type		Semi-Vortex
Shaft Seal		Double Mechanical Seal
		Silicon Carbide VS Ceramic / Carbon
Bearings		C3 Shielded ball bearings
Cable		PVC (CSA Certified) / H07RN-F
		6m (20ft) or longer upon request.
Materials	Pump Casing	Gray Iron
	Impeller	Synthetic Polymers
	Motor Frame	Aluminum
	Motor Shaft	Stainless Steel
	Outer Case	Aluminum
	Strainer	Carbon Steel
Max. Liquid Temperature		40°C (104°F)
Max. Submersion Depth		20m (66ft)
pH Range		pH 5 - pH 8